

Optimal Capacity Adjustment of Manufacturing Systems

Manufacturing industries and logistics are confronted with many challenges, in particular with respect to an increasing volatility of the market. The volatile demands may include production types, quantities and delivery dates. Both products shortages and surpluses will induce losses for the manufacturers. Therefore, balancing the relationship between demand and supply is an important problem. Moreover, the system itself may be subject to uncertainties, e.g. machine faults or non-qualified products. If those problems cannot be solved in time, they will decrease the output. Thus, the motivation of the research is to improve the ability of manufacturing factories to deal with the volatile demand and self-uncertainties effectively.

Capacity adjustment is an effective approach to react to those problems. However, most approaches of capacity adjustment are relying on labor activities, which are becoming more expensive. A new opportunity for adjusting the capacity is given by reconfigurable machine tools, which depending on their configuration may be used for different tasks on the shop floor. The main purpose of this project is to develop a control strategy, which is optimal with regards to logistic performance criteria and able to improve the potential of this process to effectively react on short and medium term fluctuations in the demand.

Problem Definition

Demand fluctuations considering product types, quantities and delivery dates render the manufacturing process highly dynamic. To cope with the dynamic, the key requirement is the ability to provide or adjust the capacity efficiently within the manufacturing process. To avoid shortages, the required capacity is typically overestimated during the strategic planning. Hence, if the capacity is static, i.e. the respective machine can be used for a single purpose only, the idle time of these machines will either be large, or if the required capacity is underestimated, functional shortages may occur.

To circumvent these issues, capacity adjustment strategies can be used on the short or mid term level. For the machine tools, there are mainly three types: Dedicated Machine Tools (DMTs), Flexible Machine Tools (FMTs) and Reconfigurable Machine Tools (RMTs). As illustrated in the figure, DMTs as the traditional machine tools are custom-designed for specific operation requirements with high productivity and low cost. These machines cannot be costeffectively converted to adjust manufacturing capacity. FMTs exhibit flexible functionality for producing a high number of variants with low volume and high cost; RMTs are permanently, quickly and cost efficiently adaptable to new manufacturing processes. Thus, RMTs are suitable for the capacity adjustment. Yet, these machine tools are only an enabler for the capacity adjustment of manufacturing system. To render capacity adjustment effectively, we need to complement these tools with respective control strategies. Like the brain of the body, control strategies are the mind of the system, which will induce an effective manner to adjust the capacity according to the status of the system.

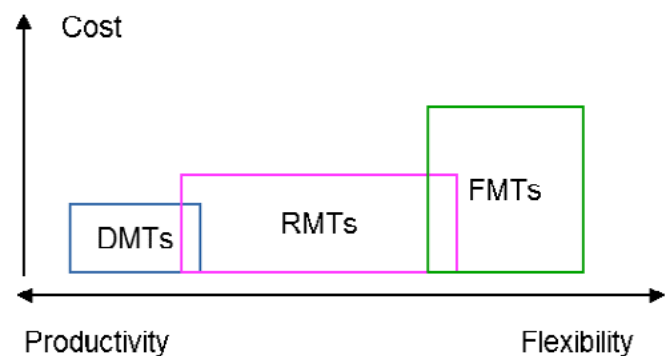

Classification of Manufacturing Machine Tools

Due to its high percentage of parallel machines, job shop manufacturing is of particular interest for the use of reconfigurable machine tools. The figure below shows an example of job shop manufacturing system with RMTs. Here, workshops are spatial and organizational units that constitute centers of concentrated knowledge and equip-



Dr.-Ing. Ping Liu
M.Sc.

Faculty of Production
Engineering

Zhengzhou, China
Finished in July 2019

International Graduate School for Dynamics in Logistics
Contact: Dr.-Ing. Ingrid Rügge

Universität Bremen
Hochschulring 20
28359 Bremen, Germany

www.logistics-gs.uni-bremen.de
info@IGS.LogDynamics.de

ment. Additionally, job shops are highly flexible, which is of particular interest in the presence of changing products. Using reconfigurable machine tools together with respective control strategies appears to be a suitable way for companies to deal with small lot sizes and a large product variety. Within our setting, we assume the percentage of reconfigurable machines to be fixed and machines to be reconfigurable in less than two hours. Moreover, the demand fluctuations are considered to be Gaussian distributed.

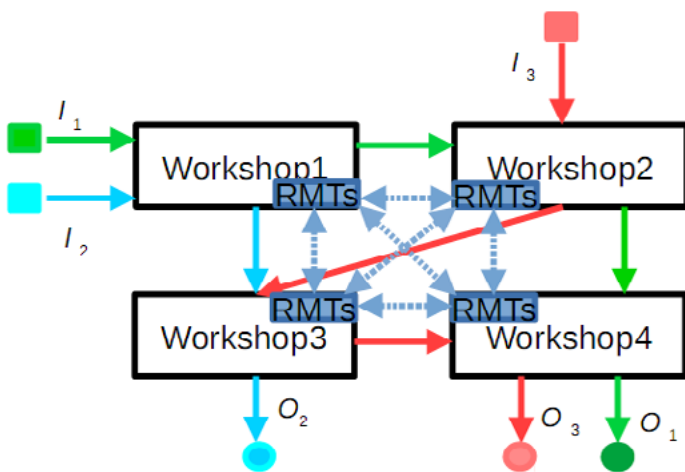

Job-Shop Manufacturing System with RMTs

To avoid shortages and unused capacities of different shop floors, the capacities of all shop floors shall be considered simultaneously. While the controller should reflect the distributed physical nature of the system, the goal of the feedback is for one to dampen the negative effects of internal and external demand fluctuations, but secondly also to improve the reliability of the logistic efficiency of the manufacturing system, i.e. short processing times with low variance and adherence to delivery dates. Last, the control shall allow for a sustainable layout of the job shop. To design such a feedback, the derivation and parameterization of different strategies and logics to trigger and execute the control must be analyzed.

Research Approach

From the problem definition, it is clear that a combination of new technology and new control concepts appears promising to countermeasure demand fluctuations in short and medium term.

Here, we will apply the operator based right coprime factorization to stabilize the system and keep it within its operational bounds. At the same time, we optimize the system

input with regards to predefined performance indicators. Applying a bottomup approach to construct the feedback according to the dynamics of the manufacturing system, we propose the following work packages:

- Modelling and analyzing the properties of reconfigurable machine tools as well as job shop manufacturing system
- Implementing control strategies, such as Operator Theory, to compute a controller for a basic Single Input Single Output (SISO) subsystem and programming of a simulation tool
- Increasing the complexity of the basic SISO subsystem to a Multiple Input Multiple Output (MIMO) system and simulating the results
- Incorporating disturbance into the MIMO system and assessing the properties of control strategies

Expected Outcome

We propose to combine the new technology of reconfigurable machine tools with advanced control strategies in order to control the capacity of job shop manufacturing systems. It will develop the potentiality of reconfigurable machine tools and extend the application of the operator-based robust right coprime factorization control method. In the job shop manufacturing systems, dedicated machine tools and reconfigurable machine tools are utilized to improve the productivity and ensure the flexibility, respectively. In academia, we expect this research will provide a suitable mathematical model including these two kinds of machines. Additionally, this proposed method will be able to deal with delays (e.g. reconfiguration delay and time-varying transportation delay), disturbances (e.g. rush orders), couplings and other difficult problems to ensure the work-in-process levels of all workstations on the predefined levels while the orders output rates satisfy the input rates in the systems.

For the manufactures, the expected outcome includes two parts. On the one hand, we will provide a new method for the manufactures to solve bottlenecks, unbalanced capacities and uncertainties in the production process. On the other hand, we expect to assist manufacturers to cope with customers' quickly-changing demands (e.g. types of products and quantities), decrease the inventory cost and improve the competitiveness in today's market.